



VEILUX®

COLOR DOME CAMERA

SVD-48



SPECIFICATIONS

ITEM	SVD-48	
Signal System	NTSC	PAL
Scanning System	2: 1 Interlace	
Scanning Freq' (H)	15.734 KHz	15.625 KHz
Scanning Freq' (V)	59.94 Hz	50 Hz
Image Sensor	1/3" SONY Super HAD CCD	
Sync. System	Internal	
Resolution	480 TV Lines (Color)	
Video Output	1.0 Vp-p composite video at 75ohm	
Lens	Fixed lens(f=3.8mm F2.0)	
Min. Illumination	0.3Lux	
Electronic Shutter	1/60~1/10,000 sec.	1/50~1/10,000 sec
Focus	Manual	
White Balance	Auto	
In/Out Connector	Power input (Red jack), Video output (Yellow jack)	
Power Consumption	150mA / 1.8W(max.)	
Dimensions	85(φ) x 76.7(H) mm	
Weight	Approximately 220g	

FEATURES

- 1/3" SONY Super HAD CCD
- Built-in Fixed Lens (f=3.8mm)
- 480 TV Lines
- Min. illumination: 0.3Lux
- Automatic White Balance
- Automatic Gain Control
- Back Light Comp'
- 85mm Dome Size

DIMENSION

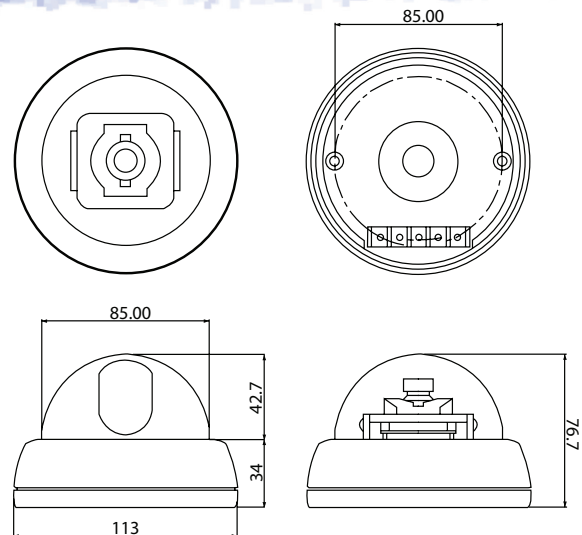

VEILUX®

The Art of Surveillance