



VEILUX®

COLOR DOME CAMERA

SVMD-42



MIRROR FUNCTION **BB**

0.01 LUX

BLC Back Light Compensation OFF ON

VOLTAGE 12DC

3-AXIS

420 TV LINES

SPECIFICATIONS

| ITEM | SVMD-42 | |
|----------------------|----------------------------|--------------------------|
| Signal System | NTSC | PAL |
| Image Sensor | 1/3" SONY Super HAD CCD | |
| CCD Total Pixel | 270,000 | 320,000 |
| Sync. System | Internal | |
| Scanning System | 525 Lines, 60 Fields/sec | 625 Lines, 50 Fields/sec |
| Min. Illumination | 0.01Lux F2.0 | |
| Lens Mount | 3.6mm Lens (Option 2.45mm) | |
| Resolution | 420 TV Lines (Color) | |
| S/N Ratio | More than 48db (AGC OFF) | |
| Electronic Shutter | 1/60~1/100,000 sec. | 1/50~1/100,000 sec |
| Gamma Correction | $\gamma=0.45$ | |
| Operational Temp' | -10°C ~ 50°C | |
| Operational Humidity | Within 90% RH | |
| Dimensions | 78.5(Ø) x 50(H) mm | |
| Power Supply | 12VDC / 90mA (Max) | |
| Weight | Approximately 147g | |

FEATURES

- 1/3" SONY Super HAD CCD
- 420 TV Lines
- Mirror Function
- 3-Axis Gimbals
- Poly Carbonate Clear Cover
- Back Light Compensation
- Vivid Sharp Picture
- High Sensitivity, Low Smear, High Anti-Blooming

DIMENSION

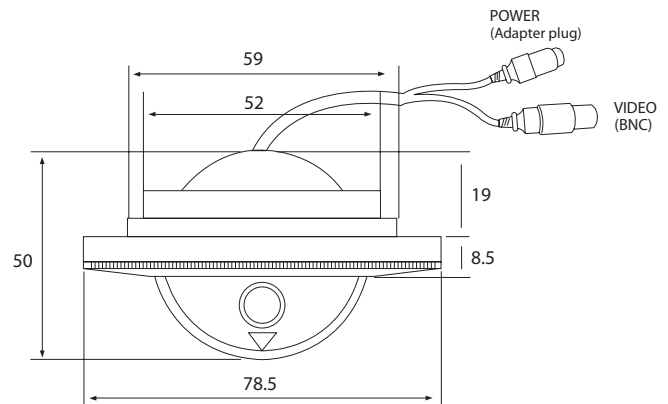

VEILUX®

The Art of Surveillance

3015 Eagle Drive, Suite 100, Grand Prairie, Texas 75052
Local Number: (214) 635-4855 / Fax: (928) 437-6270
sales@veilux.net
www.veilux.net