



# VEILUX®

## COLOR DOME CAMERA

### SVD-48IR28



## SPECIFICATIONS

ITEM	SVD-48IR28	
Signal System	NTSC	PAL
Scanning System	2: 1 Interlace	
Scanning Freq' (H)	15.734 KHz	15.625 KHz
Scanning Freq' (V)	59.94 Hz	50 Hz
Image Sensor	1/3" SONY Super HAD CCD	
Sync. System	Internal	
CCD Total Pixel	811(H) X 508(V) 410K	795(H) X 596(V) 470K
Effective Pixel No.	768(H) X 494(V) 380K	752(H) X 582(V) 440K
Resolution	480 TV Lines	
Video Output	1.0 Vp-p composite video at 75ohm	
IR LEDs	28 Units 850nm (20,000 Hours)	
S/N Ratio	More than 48db (AGC OFF)	
Lens	Fixed Lens (f=3.6mm)	
Min. Illumination	0.3Lux	
Gain Control	Auto	
Back Light Comp'	Auto	
Electronic Shutter	1/60~1/100,000 sec.	1/50~1/100,000 sec
Focus	Manual	
White Balance	Auto	
In/Out Connector	Power (Red jack), Video (Yellow jack)	
Power Supply	9VDC~15VDC (Recommendation 12VDC)	
Power Consumption	Less than 150mA	
Dimensions	85(Ø) x 76.7(H) mm	
Weight	Approximately 220g	

## FEATURES

- 480 TV Lines
- 1/3" SONY Super HAD CCD
- Built-in Fixed Lens (f=3.6mm)
- 28 Units Infrared LED
- Min. illumination: 0.3Lux
- Back Light Compensation
- Stabilized images by reducing flickering
- Automatic White Balance / Automatic Gain Control

## DIMENSION

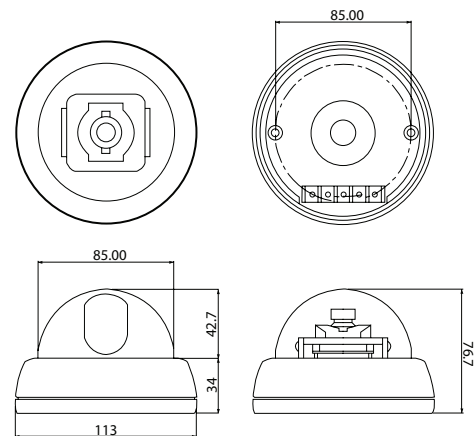

# VEILUX®

*The Art of Surveillance*

3015 Eagle Drive, Suite 100, Grand Prairie, Texas 75052  
 Local Number: (214) 635-4855 / Fax: (928) 437-6270  
[sales@veilux.net](mailto:sales@veilux.net)  
[www.veilux.net](http://www.veilux.net)