

# PRODUCT SPECIFICATION

DOCUMENT NUMBER VH8/16/3239	MODEL <b>VH839, VH1639 &amp; VH3239</b>
REVISION NUMBER 080205	8, 16 & 32 Port UTP Video Hub; up to 1,000 ft. with passive transceivers up to 3,000 ft. with active receivers

## Description

**8, 16 or 32 Port Video Balun Hubs with built-in surge suppression. Systems operate with other NITEK UTP video equipment including, Video Balun Hubs, standard Video Balun Transceivers or Active Receivers.**

The **VH839, VH1639 & VB3239** Video Balun Hubs are multi-channel video transmission devices that provide a low cost means of sending quality live video over Category UTP cabling. The systems can also adapt to existing communication and computer network spare pairs, or new cable installations. The VH839, VH1639 and VH3239 can send video up to 1,000 feet when used with other products in the VB37 or VB39 family (750 feet when used with DVR equipment). When used with model TR515 or TR560 active receivers, distances of 1,500 feet and 3,000 feet, respectively, can be attained. The VH839, VH1639 and VH3239 are designed to provide superior immunity from noise and interference, such as RFI and EMI.

## Features

- Quality video over ordinary twisted pair cable
- Built-in protection from power surges and transients
- High immunity to noise and interference
- Passive units require no power
- Video & P/T/Z over a single pair with "up-the-coax" systems when used with passive baluns
- Highly compact, only one rack unit in height
- Conveniently integrates with NITEK Modular systems
- Video can be run in the same cable with telephone, computer signals and power



VH1639 Shown

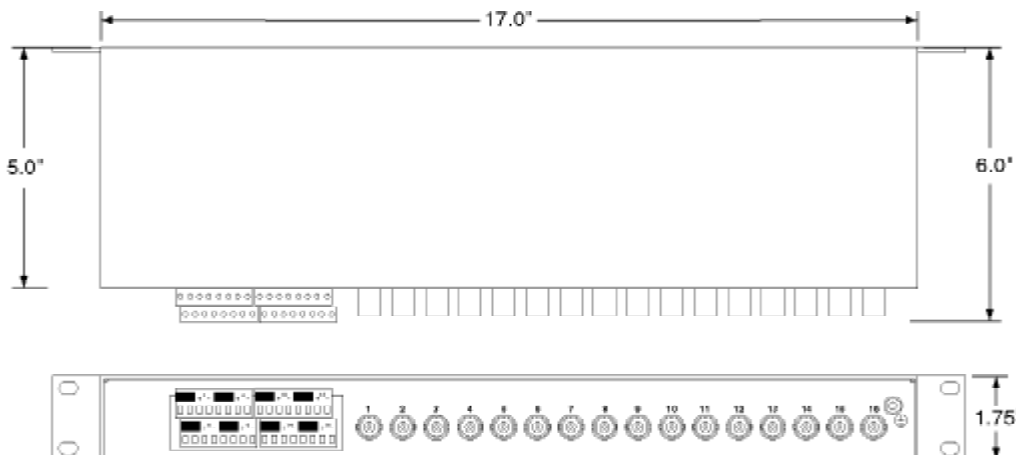

# NITEK®

5410 Newport Drive, Suite 24 • Rolling Meadows, IL • 60008  
 Phone: (800) 528-4343 • (847) 259-8900 • Fax: (847) 259-1300  
 E-mail: info@nitek.net • Internet: www.nitek.net

VH839  
VH1639  
VH3239

# TECHNICAL SPECIFICATION

## 8 Port, 16 Port or 32 Port Video Balun Hub

Size	1 RU x 6.0"D
Power Requirements	NONE REQUIRED
Video Input Connection	Standard BNC connector for 1 Vpp composite video Monochrome or Color
Video Format	RS170, NTSC, PAL, SECAM, CCIR (Color or B/W)
Twisted Pair Connection	Screw terminals providing balanced low voltage current loop
Wire Spec	26 to 12 AWG Unshielded Twisted Pair (UTP)
DC Loop Resistance	51 Ohms/1,000 ft (max)
Nominal Capacitance	17pF/ft.
Impedance	100 Ohms +/- 20%
UTP Category	2 or better
Common Mode Rejection	>70dB
Operating Frequency	DC to 10 MHz
Recommended Transmission Distance	w/passive units - Up to 1,000 feet w/active units - Up to 3,000 feet
Transient Immunity	Built-In

### Wire and Cable Recommendations

Twisted Sender is recommended for use with **unshielded twisted pair (UTP)** wiring. The systems will operate over wire gauges from 26 AWG through 12 AWG but are optimized for 24 AWG. Category cabling may be used. Individually shielded pairs should be avoided as they drastically reduce the operating range of the systems. Multi-pair cable with an overall shield is acceptable. Video can be operated in the same communication cable coexistent with telephone, computer, control signals, power voltages and other video signals. While video may be routed through telephone punch down block terminals, any bridge-taps, also called T-taps and any resistive, capacitive or inductive devices **MUST BE** removed from the pair. For more specific information regarding wire types, gauges and proper installation techniques, please call 800-528-4343 for technical assistance. More information is also available on the CCTV System Design Guide Sheet.

## Ordering Information

PART	DESCRIPTION
VH839	8 Port UTP Video Balun Hub w/surge suppression; up to 1,000 ft
VH1639	16 Port UTP Video Balun Hub w/surge suppression; up to 1,000 ft
VH3239	32 Port UTP Vide Balun Hub w/surge suppression; up to 1,000 ft
<i>VH839 or VH1639 work with the following NITEK equipment</i>	
VB37M	BNC Male Video Balun; up to 1,000 ft
VB37F	BNC Female Video Balun; up to 1,000 ft
VB39M	BNC Male Video Balun w/surge suppression; up to 1,000 ft
VB39F	BNC Female Video Balun w/surge suppression; up to 1,000 ft
TR515	Active Receiver w/surge suppression; up to 1,500 ft
TR560	Active Receiver w/surge suppression; up to 3,000 ft
VB41x4	4 Balun Card w/surge suppression for Rack; up to 1,000 ft
TR515x4	Active Receiver w/surge suppression for Rack; up to 1,500 ft
TR560x4	Active Receiver w/surge suppression for Rack; up to 3,000 ft
VH439	4 Port UTP Video Balun Mini-Hub w/surge suppression; up to 1,000 ft
VH851	8 Port Active UTP Receiver Hub w/surge suppression; up to 1,500 ft
VH1651	16 Port Active UTP Receiver Hub w/surge suppression; up to 1,500 ft
VH856	8 Port Active UTP Receiver Hub w/surge suppression; up to 3,000 ft
VH1656	16 Port Active UTP Receiver Hub w/surge suppression; up to 3,000 ft

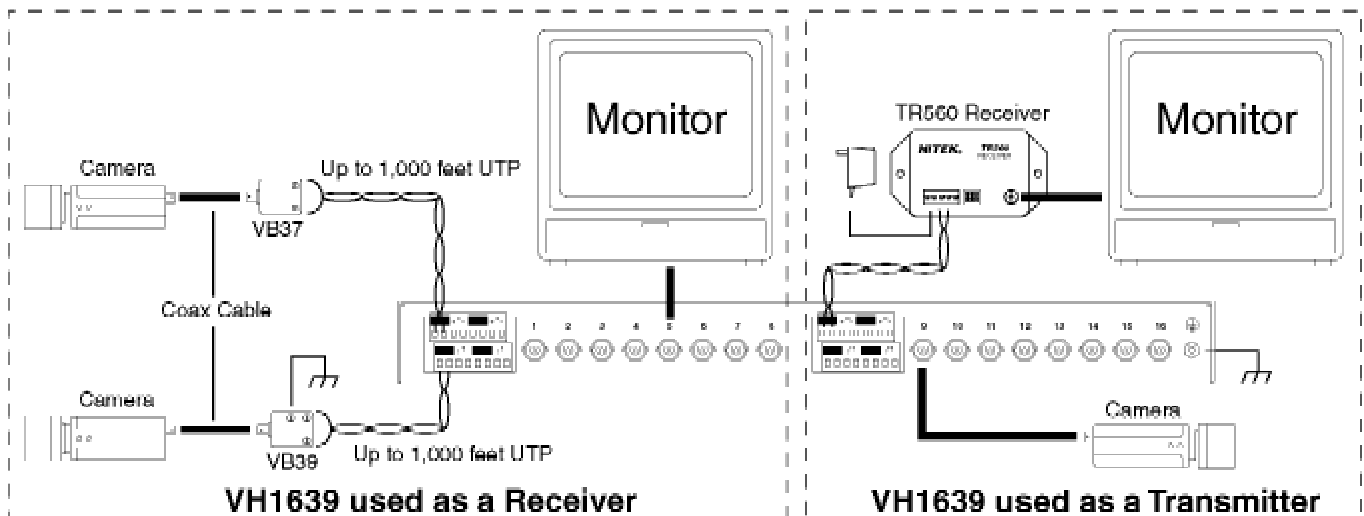

Specifications subject to change without notice.