

# JVC®

The Perfect Experience / —  
/

1/3" CCD COLOR VIDEO CAMERA

# TK-C920U(A)

(AC 24V/DC 12V)

Revolutionary Camera with 535TVL and Easy Day/Night Function

◆ **0.48 Super LoLux™**  
**lux** (in B&W Mode)

◆ **0.7 Super LoLux™**  
**lux** (in Color Mode)



Shown with optional lens.



Conventional Camera

- 1/3" High Resolution CCD with 380,000 Effective Pixels
- 535 TV Lines of Horizontal Resolution
- Easy Day/Night Function: Chroma ON/OFF
- Super LoLux™ Sensitivity: 0.7 lux F1.2 in Color Mode, 0.48 lux F1.2 in B&W Mode
- Signal-to-Noise Ratio: 50dB (AGC OFF)
- Revolutionary Integrated 10 bit Digital Signal Processor (DSP)
- Full-Featured Security Camera
  - Automatic Electronic Shutter (AES) Mode ON/OFF
  - Automatic Gain Control (AGC) ON/OFF
  - Automatic Tracking White Balance (ATW) and Manual Modes
  - Backlight Compensation ON/OFF
  - Sync Systems INT/Line Lock
  - Supports Video/DC Iris Lenses
  - C/CS Lens Compatible
  - Ultra Compact Camera Body
  - AC 24V/DC 12V Power Supply

# JVC's revolutionary 535 TVL CCD, Easy Day/Night Function and leading edge DSP combine to meet future market needs.

JVC not only satisfies customers' current demands but also anticipates their future requirements by incorporating advanced camera technologies inside the TK-C920U(A) high resolution, color surveillance camera.

The camera performs brilliantly in all the key areas. 535 TVL resolution is delivered by the 1/3" Interline Transfer CCD. The quality of key image parameters are continually optimized by the intelligent Digital Signal Processor. At 0.48 lux in B&W mode, the Easy Day/Night Function allows the camera to achieve high performance even in low light situations.

## Easy Day/Night Function

The TK-C920U(A) automatically uses color mode when the subject is bright, and B&W mode when it is dark. In B&W mode, AGC is always active to achieve high performance even in low light situations.

## Built-in Revolutionary Digital Signal Processor (DSP)

JVC's innovative Digital Signal Processor automatically adjusts camera parameters to ensure that sharp and natural pictures of 535 TV lines horizontal resolution combine with high-quality performance.

## 1/3-inch High Resolution CCD with 380,000 Effective Pixels

JVC's TK-C920U(A) comes with a 1/3-inch Interline Transfer CCD for accurate color reproduction and signal-to-noise ratio of 50 dB.

## Detail Corrections — Horizontal and Vertical (2H)

The TK-C920U(A) provides dual-edged detail correction — horizontal and vertical with 2H line memory.

## Super LoLux™ and Automatic Gain Control (AGC)

As the ambient light level falls the AGC seamlessly increases the camera's sensitivity.

With Super LoLux™ turned on the AGC will further increase the camera's sensitivity to 0.7 lux at F1.2.

## Manual or Automatic (ATW) White Balance

For flexibility of operation in a wide range of environments the white balance can be set manually or can be automatically adjusted in real time by the Automatic Tracking White Balance function over a range of 2,300°K to 10,000°K.

## Specifications

Signal system	NTSC
Pickup device	1/3" Interline-Transfer CCD (with complementary color filter)
Number of effective pixels	380,000 (768 H x 494 V)
Video processing	Built-in DSP (10 bits)
Pickup area	4.8 mm (H) x 3.6 mm (V)
Sync system	Internal, Line Lock (60Hz regions only)
Scanning system	2:1 interlaced, 525 lines
Scanning frequency	15.734kHz (H); 59.94Hz (V)
Video output	Composite video signal: 1.0 V(p-p), 75 ohms
Video S/N	50 dB (AGC OFF)
Horizontal resolution (typical)	535 TV lines
Minimum illumination (typical)	Color mode: 0.7 lux (F1.2, AGC ON, video level 25%) 1.5 lux (F1.2, AGC ON, video level 50%) B&W mode: 0.48 lux (F1.2, AGC ON, video level 25%) 1.0 lux (F1.2, AGC ON, video level 50%)
Iris control	Video iris/DC iris
White balance	ATW/Manual
BLC	ON/OFF
AES	ON/OFF (1/60 — 1/100,000 sec.)
Lens mount	C/CS
Power requirement	AC 24V (60Hz), DC 12V
Power consumption	4.7W
Operating temperature range	14°F to 122°F (-10°C to 50°C) 32°F to 104°F (0°C to 40°C) (recommended)
Regulatory standard	UL2044, FCC Part15, Class A, ICES-003
Weight	0.82 lbs. (370g)

## Controls, connectors and indicators



- 1 BACK FOCUS locking screw
- 2 BACK FOCUS adjustment and C/CS mount selector ring
- 3 Lens mount (C/CS)
- 4 Camera mounting bracket
- 5 IRIS connector
- 6 VIDEO/DC IRIS select switch
- 7 LEVEL volume
- 8 D/N (Easy Day/Night) ON/OFF
- 9 AGC (Automatic Gain Control) ON/OFF
- 10 AES (Automatic Electronic Shutter) ON/OFF
- 11 BLC (Backlight Compensation) ON/OFF
- 12 WHITE BALANCE select switch
- 13 LL/INT select switch
- 14 PHASE/W.B. select switch
- 15 PHASE/W.B. adjustment button
- 16 RESET button
- 17 Power indication

## Dimensions

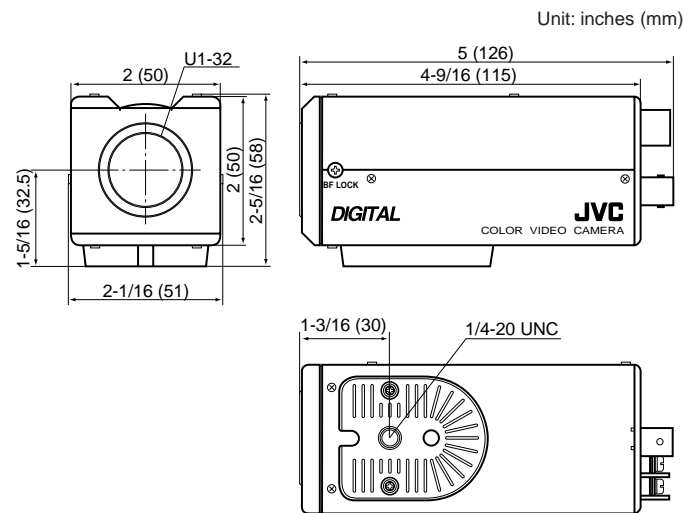

Design and specifications subject to change without notice.

# JVC®

DISTRIBUTED BY



■ The Hachioji Plant of Victor Company of Japan, Ltd., has received ISO14001 and ISO9001 Certifications under the global standard for environmental management.